

SOMETHING ABOUT THE COLLECTION.

AFTER THE SEMESTERS OF STUDY,
I HAVE A DEEPER UNDERSTANDING OF LEATHER.

ONLY GOING THROUGH THE STEPS OF CONCEPTION,
PATTERN MAKING, CUTTING, SEWING AND SO ON,

FINALLY WILL UNDERSTAND THAT WHY THE BAGS COST SUCH HIGH

THE TIME AND CONCENTRATION IS USING A LONG TIME.

I ALSO LIKE TRAVELING SO MUCH, ESPECIALLY TRAVELING ALONE.

THERE ARE OFTEN MANY NEW PEOPLE / THINGS IN THE JOURNEY,
AND LIFE IS ACTUALLY THE SAME AS THE JOURNEY.

I ALWAYS ENJOY THE MOMENT,
AND TRYING USING MY IMAGINE TO PRESENT MYPRODUCT.

TABLE OF **CONTANT**

1. I'M STILL ALIVE
2. ONLY HAVE 50%
3. OPEN COFFIN
4. SET ME FREE



I'M STILL ALIVE

「偽りの情愛でいいよ
道化師だって演じ切るから」



我
仍
活
着
I'M STILL ALIVE



WHILE I'M STILL ALIVE

MATERIAL ARTIFICIAL LEATHER

SIZE 19.5CMX5.5CMX12CM

FINISH DATE 2019/04/09





ONLY HALF



MATERIAL ARTIFICIAL LEATHER

SIZE 21CMX11CMX13.4CM

FINISH DATE 2019/06/16

OPEN



COFFIN

MATERIAL ARTIFICIAL LEATHER
SIZE 24.4CM X 9CM X 8CM
FINISH DATE 2019/06/18



"LOST YOUR SOUL..."



SET ME FREE

REBORN



"YOU WILL BE A NEW PEOPLE..."



MATERIAL ARTIFICIAL LEATHER
SIZE 20CMX12CMX11CM
FINISH DATE 2019/06/19

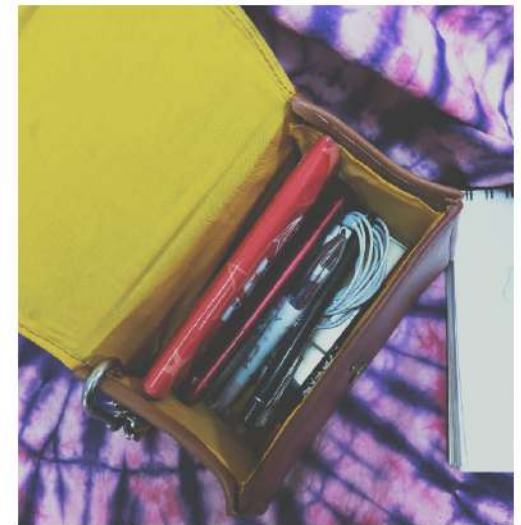



ABOUT MYSELF

STUDENT

KAOSHIUNG ,TW

IRENEONLAM28@GMAIL.COM

+886 909539365

ANYABALAJA0425

ON LAM

EVERYONE HAS A STORY OF THEIR OWN,
BUT HOW TO PRESENT THE MOST LIVES IN A LIMITED TIME,
IT DEPENDS ON WHETHER THE DESIGNER CAN TELL THE STORY AS VIVID AND ELOQUENT.

EDUCATION:

SHU-TE UNIVERSITY, BACHELOR DEGREE, ACCESSORY, 2017 ~

STUDENT UNION INFORMATION TEAM MEMBERS OF DEPARTMENT OF FASHION DESIGN

-ASSIST IN THE INVESTIGATION AND PUBLICATION OF EVENT INFORMATION

DESIGN RELATED SKILL

PHOTOSHOP

DRAWING
RECOVER IMAGE
EDIT IMAGES

ILLUSTRATOR

CREATE PICTURES
LOGO DESIGN

INDESIGN

TYPOGRAPHY DESIGN
LAYOUT DESIGN

PREMIERE PRO

EDITING VIDEO
CREATE SPECIAL EFFECT

DREAMWEAVER

CREATE WEBSITE
BUILDING HTML

WORD

REMARK PROJECT
CHINESE TYPING 30 WORDS/MINUTE
ENGLISH TYPING 50 WORDS/MINUTE

ABOUT LANGUAGE



CATONESE

MONTHER LANGUAGE

MANDARIN

SECOND MOTHER LANGUAGE

PUTONGHUA SHUIPING CESHU (GRADE :FIRST CLASS LOWER)

ENGLISH

SECOND MOTHER LANGUAGE

TOEIC (GRADE :550)

JAPANESE

JAPANESE LANGUAGE PROFICIENCY TEST(GRADE :N3)

迷失異空

人類所產生的污染日漸增多，各國政府為逃避處理費用將大部分垃圾發射往太空。

人類與外星人在宇宙探索之間，被垃圾環流牽扯，發現原來夜空閃閃發光的星辰是人類每日產生的廢物。



心智圖

迷失異空--宇宙流浪

靈感來源：環境污染+太空未來

設計理念：

天空閃閃發光的星辰，墜落下的流星不過是人類自己作下的孽罷了。

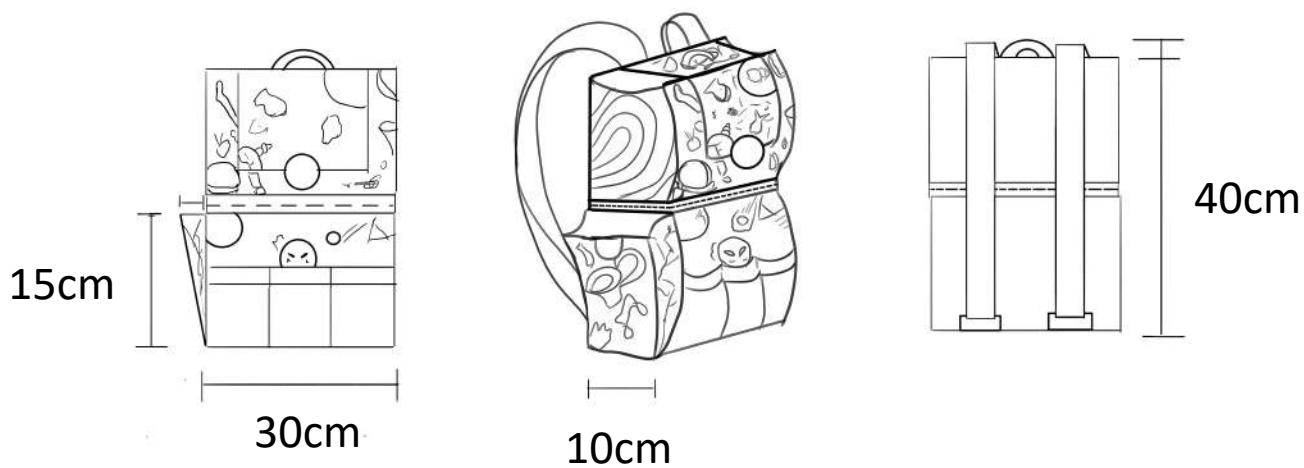

PU人造皮革

迷失異空--迴夢傾頹

靈感來源：太空探索，ASCII密碼

設計理念：闖入垃圾環流之中，驚覺太空人在其中悠然自得。

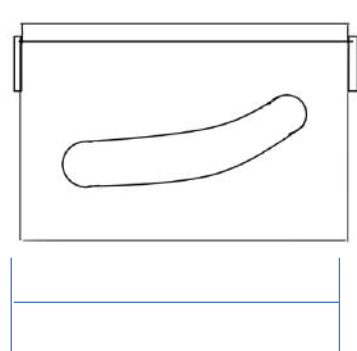
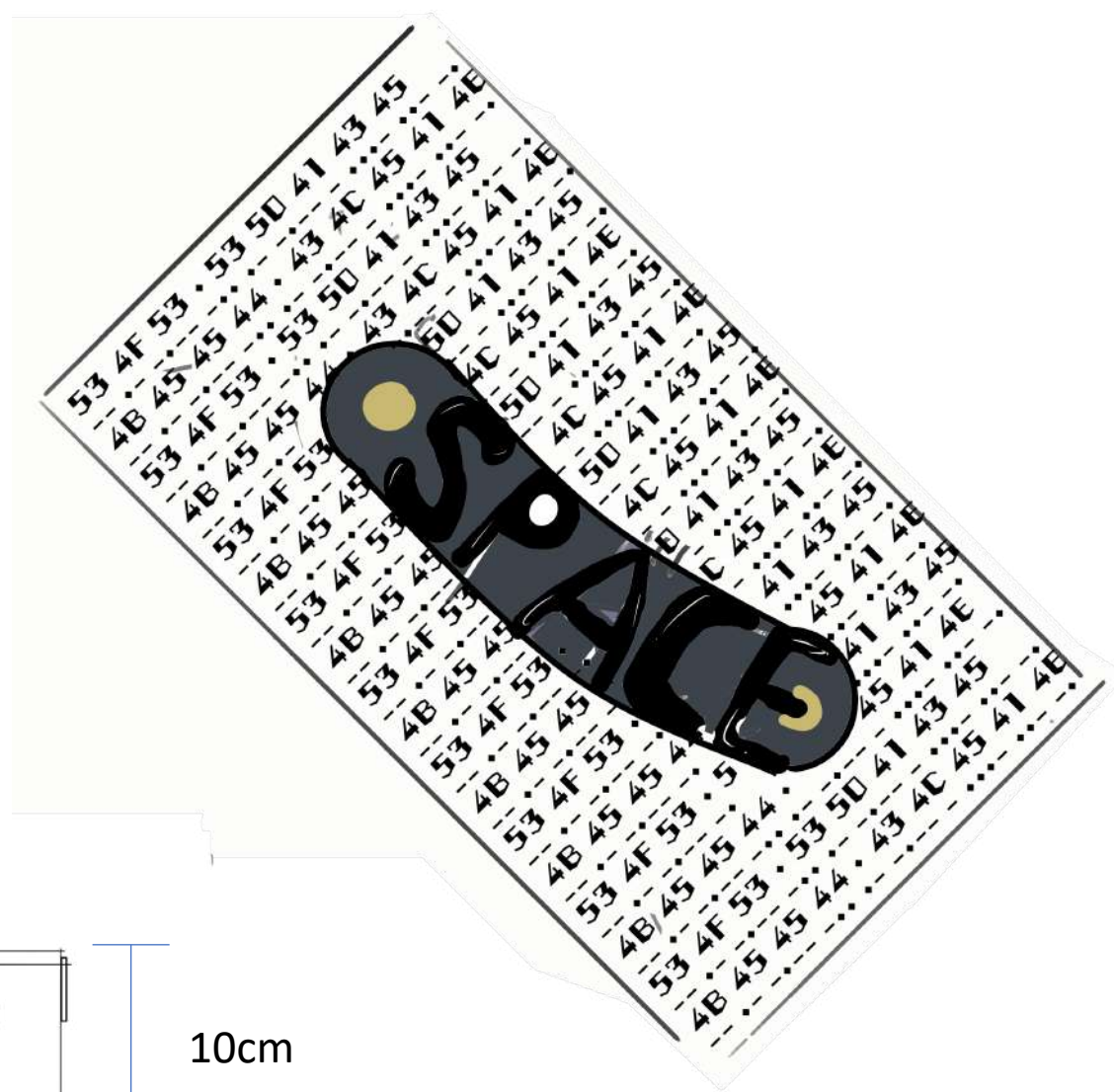

15cm



2cm

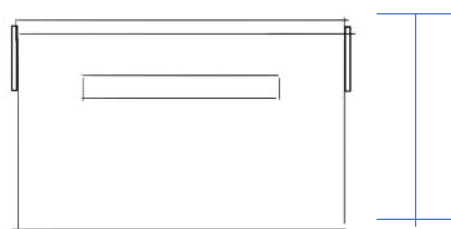

10cm

十字紋牛皮



PU人造皮革

迷失異空

靈感來源：太空探索，ASCII密碼，摩斯密碼

設計理念：發現無法脫離環流牽引，遂發出求救，奈何受垃圾干擾，始終無法傳遞完整訊息。

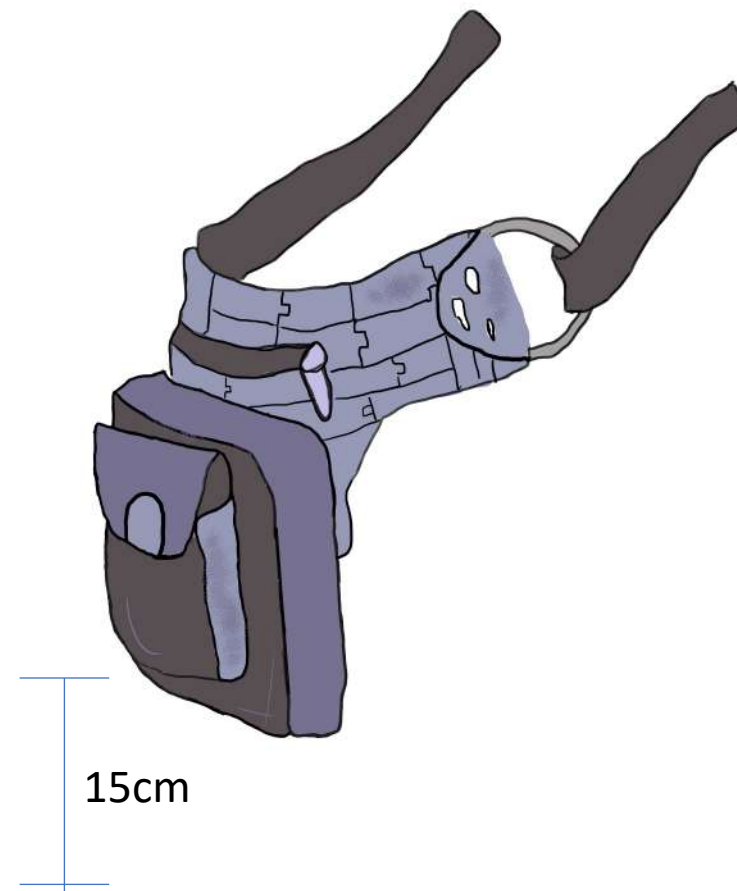
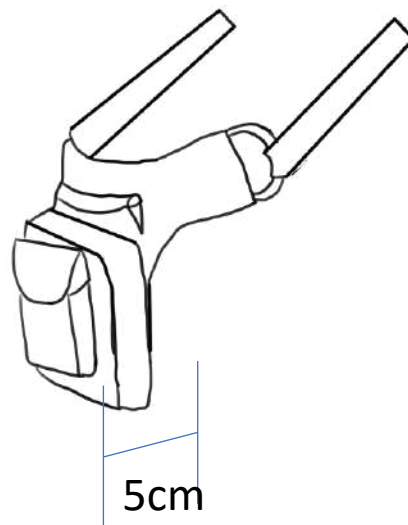
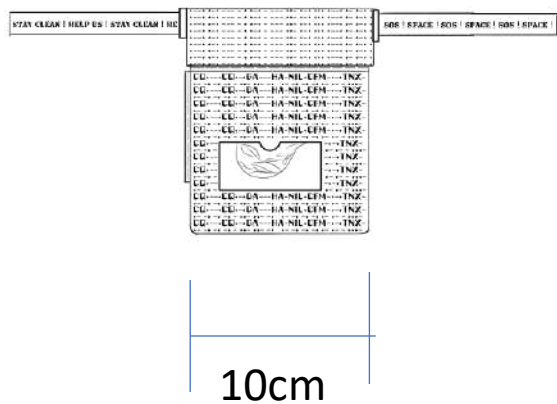

PU人造皮革

參賽設計圖（共九款）

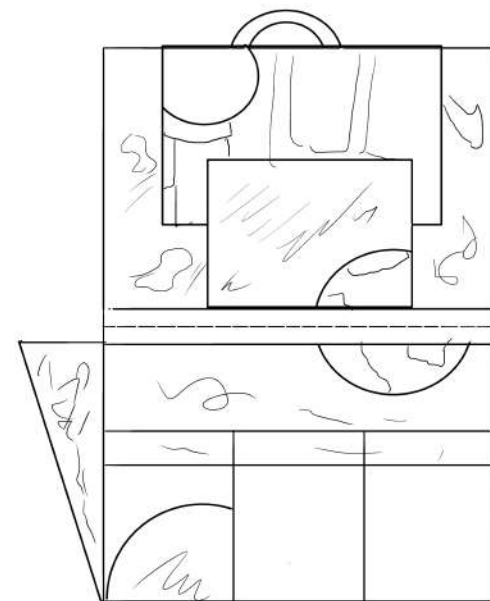

參賽設計圖 (共九款)

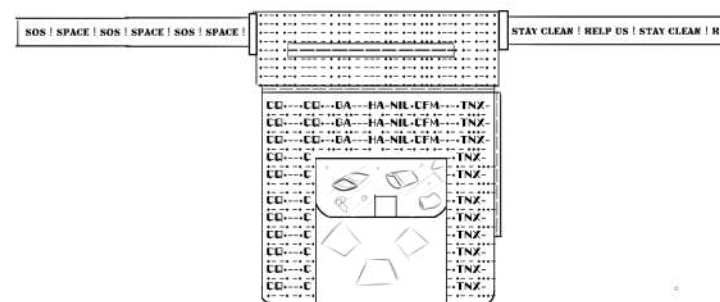
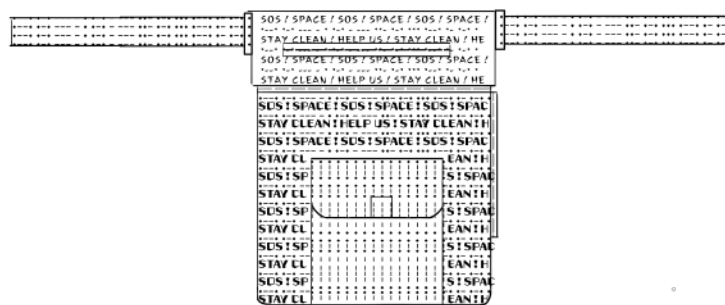
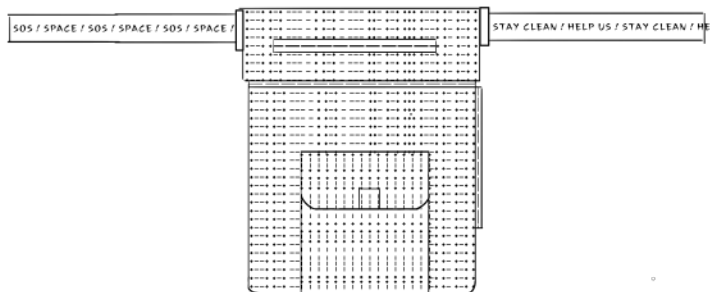

二十七種配色圖

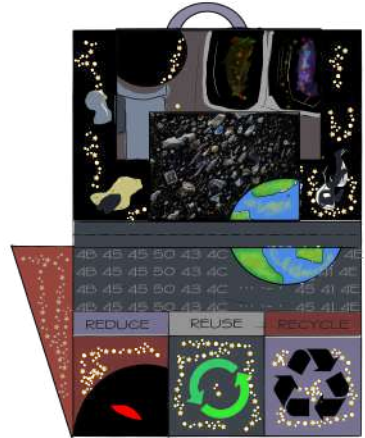
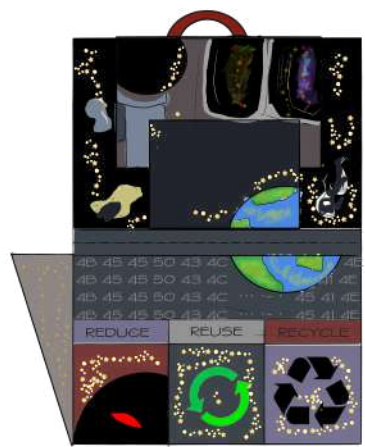
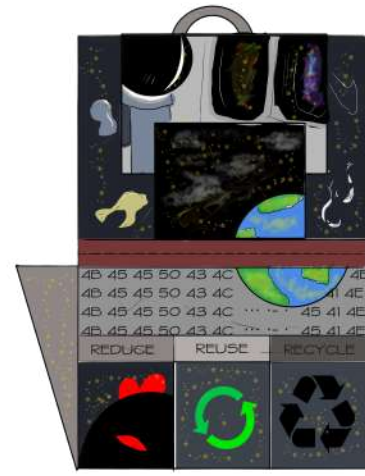
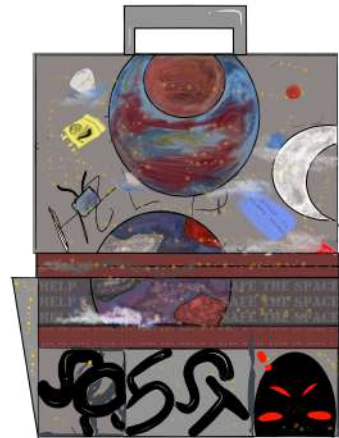
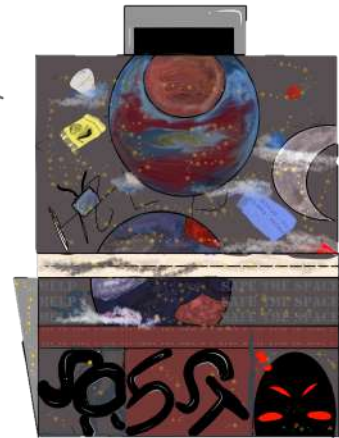
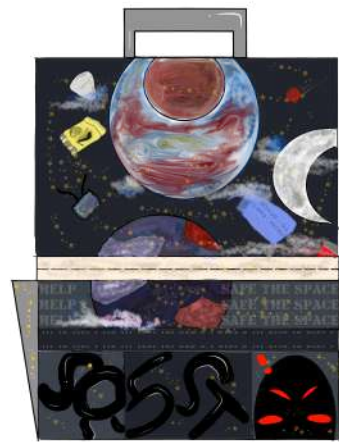
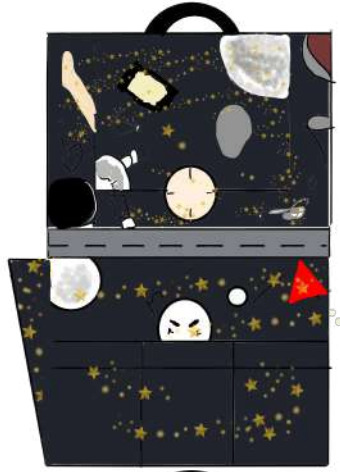

二十七種配色圖

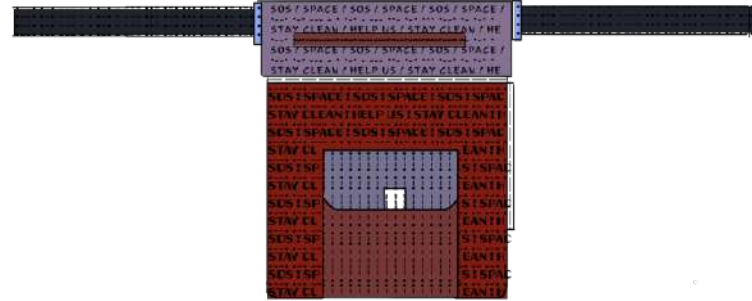
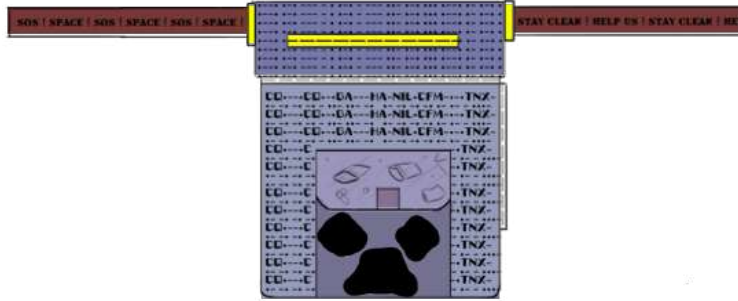
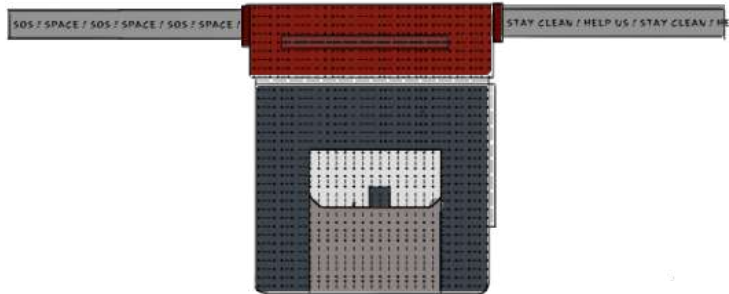
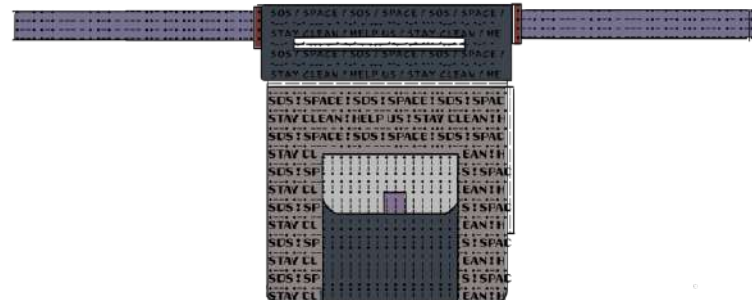
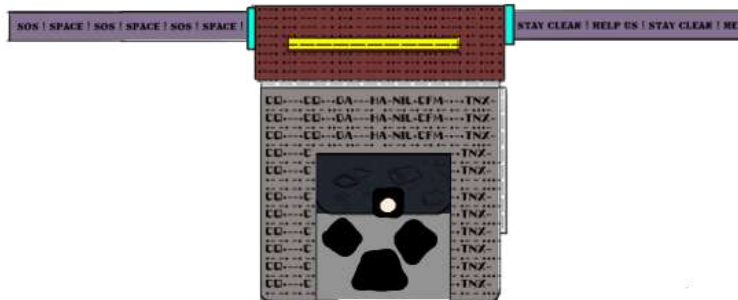
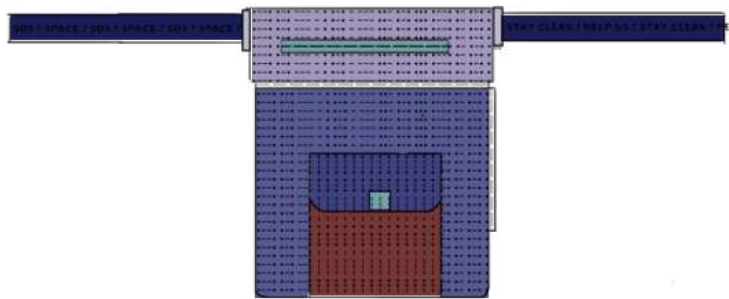
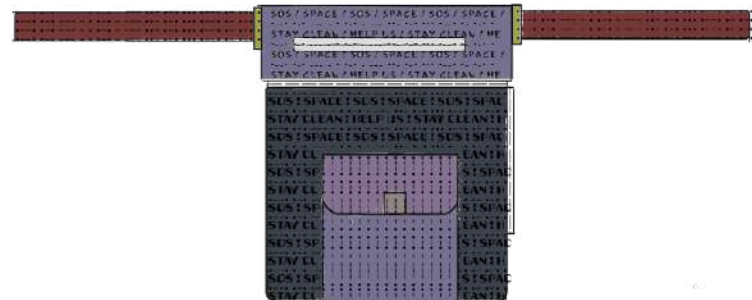
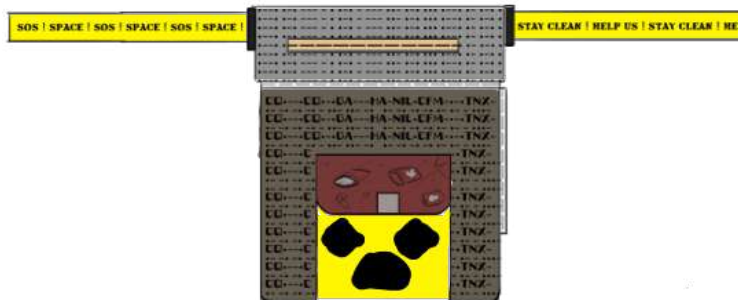
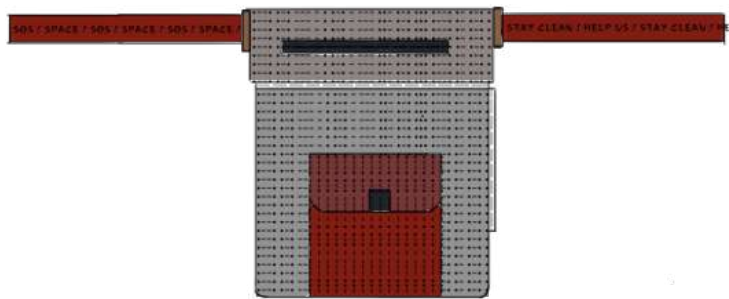

二十七種配色圖

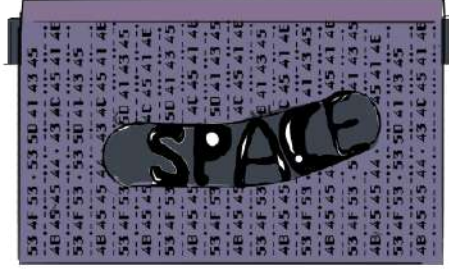
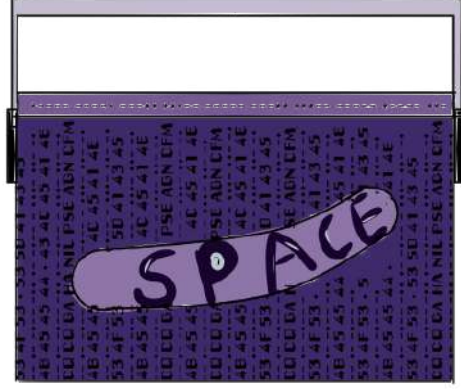
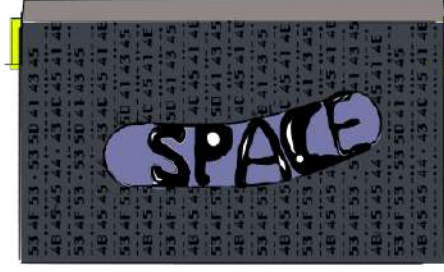
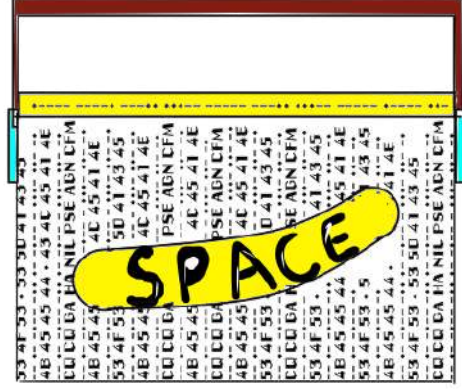

夏

Summer 2020 collection

一個難忘的夏天
一段被浸泡在可可巧克力裡的苦澀回憶。

這次作品主要分為證件夾、短夾跟長夾，
也很特別地嘗試了用鉻鞣皮革來進行製作。



成品們的合照。
誰也沒想到他們會是我兩年
主修課裡最滿意的作品。

概念故事

世界很大 我跟你的距離 卻很小

I'll be there for you if you should need me

你是彼粒星 飛過我的天頂



有些時候，
連自己都不太清楚自己的心意，
想要鼓起勇氣跟對方告白，卻又害
怕自己的莽撞把事情結果弄得更糟
糕。



MY LOVE
きみにとどけ

■
[君と出会ったこと 離れても忘れない]

呐!
我們一起逃離這個夏天吧!

[いつまでも一緒にいたい]



靜態攝影



• SUMMER •

動態攝影



END.